



COMPACT

MICROPROCESSOR-BASED DIGITAL ELECTRONIC FREEZER CONTROLLER



Operating Instructions

- 3.2 MECHANICAL MOUNTING
- 3.3 ELECTRICAL CONNECTIONS
- 3.4 ELECTRICAL WIRING DIAGRAM
- 4 FUNCTIONS**
- 4.1 MEASURING AND VISUALIZATION
- 4.2 ROOM PROBE PEAK VALUES MEMORIZATION
- 4.3 OUTPUTS CONFIGURATION
- 4.4 TEMPERATURE CONTROL
- 4.5 CONTINUOUS CYCLE FUNCTION
- 4.6 COMPRESSOR PROTECTION FUNCTION AND DELAY AT POWER-ON
- 4.7 DEFROST CONTROL
- 4.8 MANUAL DEFROST
- 4.9 EVAPORATOR FANS CONTROL
- 4.10 ROOM LIGHT CONTROL
- 4.11 ALARM FUNCTIONS
 - 4.11.1 TEMPERATURE ALARMS
 - 4.11.2 EXTERNAL ALARM
 - 4.11.3 OPEN DOOR ALARM
 - 4.11.4 ALARM MEMORY
- 4.12 DIGITAL INPUT
- 4.13 AUXILIARY OUTPUT
- 4.14 FUNCTION OF KEYS "U" AND "DOWN/AUX"
- 4.15 PARAMETERS CONFIGURATION BY KEY USB
- 5 PROGRAMMABLE PARAMETERS TABLE**
- 6 PROBLEMS , MAINTENANCE AND GUARANTEE**
- 6.1 SIGNALLING
- 6.2 CLEANING
- 6.3 GUARANTEE AND REPAIRS
- 7 TECHNICAL DATA**
- 7.1 ELECTRICAL DATA
- 7.2 MECHANICAL DATA
- 7.3 MECHANICAL DIMENSIONS, PANEL CUT-OUT AND MOUNTING
- 7.4 FUNCTIONAL DATA
- 7.5 INSTRUMENT ORDERING CODE

FOREWORD



This manual contains the information necessary for the product to be installed correctly and also instructions for its maintenance and use; we therefore recommend that the utmost attention is paid to the following instructions and to save it.

This document is the exclusive property of OSAKA which forbids any reproduction and divulgation , even in part, of the document, unless expressly authorized.

OSAKA reserves the right to make any formal or functional changes at any moment and without any notice.

Whenever a failure or a malfunction of the device may cause dangerous situations for persons, thing or animals, please remember that the plant has to be equipped with additional devices which will guarantee safety.

OSAKA . and its legal representatives do not assume any responsibility for any damage to people, things or animals deriving from violation, wrong or improper use or in any case not in compliance with the instrument's features.

INDEX

- 1 INSTRUMENT DESCRIPTION**
- 1.1 GENERAL DESCRIPTION
- 1.2 FRONT PANEL DESCRIPTION
- 2 PROGRAMMING**
- 2.1 PROGRAMMING OF SET POINT
- 2.2 PARAMETERS PROGRAMMING
- 2.3 PARAMETER PROTECTION USING THE PASSWORD AND KEYBOARD LOCK FUNCTION
- 2.4 PARAMETERS PROGRAMMING LEVEL
- 2.5 ACTIVE SET POINT SELECTION
- 2.6 ON / STAND-BY FUNCTION
- 3 INFORMATION ON INSTALLATION AND USE**
- 3.1 PERMITTED USE

1 - INSTRUMENT DESCRIPTION

1.1 - GENERAL DESCRIPTION

The model COMPACT is a digital controller with microprocessor that is typically used in cooling applications that have temperature control with ON/OFF regulation and defrosting control with set time by means of electrical heating or hot gas/reverse cycle. The instrument has up to 4 relay outputs, two inputs for PTC or NTC temperature probes and a digital input, that can all be configured.

The 4 outputs can be used for controlling the compressor or the temperature control device (OUT), the defrosting device (DEF), the evaporation fan (FAN), the room light (LIGHT) or, alternatively any of the previous functions, using an auxiliary device (AUX) or an alarm (AL). The two inputs for the PTC and NTC temperature probes (which can be selected by parameter) can be used to measure the cell temperature (Pr1) and the evaporator temperature (Pr2) while the digital input (DIG) can be programmed to carry out various functions such as defrosting commands, selecting a different set of temperature regulations, external alarm signals, activating a continuous cycle, and activating an auxiliary output etc.

The instrument is equipped with 7 programme keys, a 4-digit display and 9 LED signals, in addition to an internal buzzer that is the sound system for alarms. Other important characteristics of the instrument are: programme parameters protection using personalised password, Keyboard lock function, switching on and off (stand-by) of the instrument using the front keys or the digital input, configuration of parameters via the KEY USB device, memorising of two sets of temperature regulations that can be switched and the possibility of power supply in the range 100 ... 240 VAC.

1.2 - FRONT PANEL DESCRIPTION

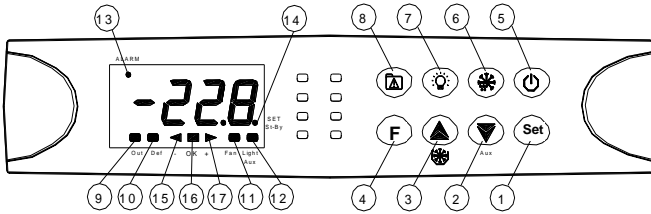

1 - Key P : Used for setting the Set point and for programming the function parameters

2 - Key DOWN/AUX : Used for decreasing the values to be set and for selecting the parameters.

Outside the programming mode it permits visualisation of the minimum room probe (Pr1) peak measure.

It can also be programmed via the parameter "Fbd" to carry out other functions such as activating the Aux output or selecting the active set point (see par. 4.14).

3 - Key UP/CONT. CYCLE : Used for increasing the value to be set, for selecting the parameters and for starting up the continuous cycle. Outside the programming mode it permits visualisation of the maximum room probe (Pr1) peak measure.

4 - Key U : Used for visualising the temperatures taken by the cell probes and evaporator (Pr1 and Pr2). It can also be programmed via the parameter "USrb" to carry out other functions, just like the key DOWN/AUX (see par. 4.14).

5 - Key ON/OFF(Stand-by) : Used for turning on and off (stand-by) the device

6 - Key DEFROST : Used for activating manual defrosting

7 - Key LIGHT : Used for activating Light output

8 - Key Not used

9 - Led OUT : Indicates the compressor output status (or the temperature control device) on (on), off (off) or inhibited (flashing)

10 - Led DEF : Indicates defrosting in progress (on) or dripping (flashing).

11 - Led FAN : Indicates fan output status on (on), off (off) or delayed after defrosting (flashing)

12 - Led LIGHT/AUX : Indicates LIGHT and AUX outputs status.

OFF : both outputs are OFF

Alternately flashing and OFF: LIGHT output ON and AUX output OFF

Alternately flashing and ON: both outputs are ON

Alternately OFF and ON: LIGHT output OFF and AUX output ON

13 - Led AL : Indicates the alarm status (on), off (off) and silenced or memorized (flashing)

14 - Led SET/STAND-BY : Indicates the input in programming mode and the programming level of the parameters. It also serves to indicate the Stand-by status.

15 - Led - : Indicates that a low temperature alarm is in progress (lit) or that a low temperature alarm has been memorised (flashing).

In Room Peak values mode it indicate the minimum value

16 - Led OK : Indica che non vi sono allarmi in corso

17 - Led + : Indicates that a high temperature alarm is in progress (lit) or that a high temperature alarm has been memorised (flashing). In Room Peak values mode it indicate the maximum value.

These keys increase or decrease the value one digit at a time, but if the button is pressed for more than one second the value increase or decreases rapidly, and after two seconds pressed, the speed increases even more to all the desired valued to be reached rapidly.

Exiting the Set mode is achieved by pressing the P key or automatically if no key is pressed for 15 seconds. After that time the display returns to the normal function mode.

2.2 - PARAMETERS PROGRAMMING

To access the instrument's function parameters, press the key **P** and keep it pressed for about 5 seconds, after which the SET led will light up, the display will visualised the code that identifies the first group of parameters ("SP ") and the group of parameters that are to be edited are selected by pressing the UP and DOWN keys.

Once the group of parameters has been selected, press the P and the code that identifies the first parameter in the selected group will be visualised.

Again using the UP and DOWN keys, the desired parameter can be selected and pressing the P key, the display will alternately show the parameter code and its setting that can be changed with the UP and DOWN keys.

Once the desired value has been set, press the key P again: the new value will be memorised and the display will show only the abbreviation of the selected parameter.

Pressing the UP and DOWN keys, it is possible to select another parameter (if present) and change it as described.

To return to select another group of parameters, keep the UP or the DOWN key pressed for about 1 second, after which the display will return to showing the code of the parameter group.

Release the pressed key and using the UP and DOWN keys it will be possible to select another group (if present).

To exit the programming mode, do not press any key for about 20 seconds, or keep the UP or DOWN key pressed until it exits the programming mode.

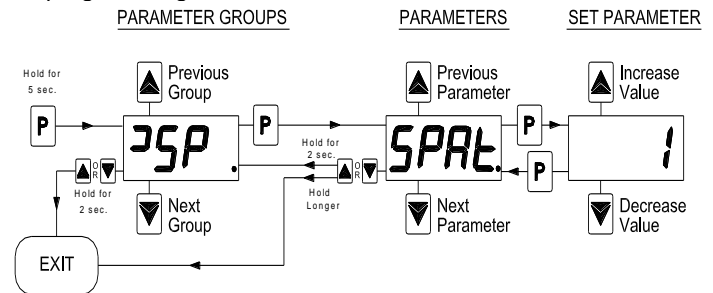

2.3 - PARAMETER PROTECTION USING THE PASSWORD AND KEYBOARD LOCK FUNCTION

The instrument has a parameter protection function using a password that can be personalised, through the "PASS" parameter in the "PAN" set.

If one wishes to have this protection, set the password number desired in the parameter "PASS".

When the protection is working, press the P key to access the parameters and keep it press for about 5 seconds, after which the LED SET will flash and the display will show "0".

At this point, using the UP and DOWN keys, set the password number programmed and press the key "P".

If the password is correct, the display will visualise the code that identifies the first group of parameters("SP ") and it will be possible to programme the instrument in the same ways described in the previous section.

Protection using a password can be disabled by setting the parameter "PASS" = OFF.

Additionally to the protection through the Password, it's possibile to lock completely the keyboard.

This function is particularly useful when the regulator is reachable by the users and it's desired to avoid any modification.

2 - PROGRAMMING

2.1 - PROGRAMMING OF THE SET POINT

Press the key **P** then release it and the display will show **SP 1** (or **SP 2** if the second set is active at that time) alternating with the set value (see selection of the active set point).

To change it press the UP key to increase the value or DOWN to decrease it.

To activate the keyboard lock it's enough to contemporarily push key UP and DOWN and keep them pushed for 3 sec. while the regulator is on.

After the 3 sec., the label "LOn" will appear on the display and all the key functions will be locked except the Set Point visualization.

When the keyboard is lock, if any of the key is pushed, on the display will appear again "LOn" to indicate the lock.

To unlock the keyboard it's enough to contemporarily push again key UP and DOWN and keep them pushed for 3 sec., afterwhitch the label "LOF" will appear on the display and all the functions will be available again to be modified.

2.4 - PARAMETERS PROGRAMMING LEVELS

The instrument has two parameter programming levels.

The first level ("visible" parameters) is accessed according to the procedure described above (with or without password request) while the second level ("hidden" password) can be accessed according to the following procedure.

Remove the power supply to the instrument, press the key P and return power to the instrument, keeping the key pressed.

After about 5 sec. the SET led will light up, the display will show the code that identifies the first group of parameters("1SP ") and it will be possible to set the parameters of the instrument using the same programming procedure described previously.

Once the parameter has been selected and the SET is on, it means that the parameter can be programmed even on the first level ("visible").

If the LED is off it means that the parameter can only be programmed on this level (i.e. "hidden").

To change the visibility of the parameter, press the key U: the led SET will change status, indicating the accessibility level of the parameter (on = parameter "visible"; off = parameter "hidden").

The access procedure for "hidden" parameters allows the "PASS" parameter to be checked and changed, and is useful therefore if the password set has been forgotten.

2.5 - ACTIVE SET POINT SELECTION

The instrument allows up to 2 different regulation Set points to be pre-set ("SP 1" and "SP 2") and then to choose which one to make active.

This function can be used if it is necessary to switch two different function temperatures (e.g. day and night or positive and negative etc).

The active set point can be selected:

- Using the parameter "SPAt"
 - using the key U if the parameter "USrb" = 2.
 - Using the key DOWN/AUX if the parameter "Fbd" = 2.
 - Using the digital input if the parameter. "diF" = 9
- (see par. 4.12 and 4.14)

The Set points "SP1" and "SP2" can be set with a value between the programmed value in parameter. "SPLL" and the programmed value in parameter "SPHL".

Note: in the examples that follow, the Set point is generally indicated as "SP", how when operating the instrument will work according to the Set point selected as active.

2.6 - ON / STAND-BY FUNCTION

The instrument, once powered up, can assume 2 different conditions:

- ON : means that the controller uses the control functions.
- STAND-BY : means that the controller does not use any control function except for the Light control and the display is turned off except for the green SET led.

If there is no power, and then power returns, the system always sets itself in the condition it was in before the black-out.

The ON/Stand-by function can be selected:

- Using the key ON/OFF hold for 1 sec.
- Using the digital input if the parameter "diF" = 11 (see par. 4.12)

3.1 - PERMITTED USE



The devices are made as measuring and regulating equipment in accordance with EN 61010-1 norm for operation up to an altitude of 2000 mts.

The use of equipment for standard applications not expressly provided in norm cited above, should provide all measurement and adjustments necessary protection.

The equipment must be adequately protected and away from liquids, dust, grease and dirt. They must be accessible only with the use of a right tool and safety system (except the front).

The devices can NOT be used in dangerous environments (flammable or explosive) without adequate protection.

It is recalled that the installer must ensure that the norm for electromagnetic compatibility is respected after implantation in the installation of equipment, eventually using the right filters if is needed.

In case of failure or malfunction of measuring and control equipment that can create dangerous situations or damage to persons, things, animals or products (defrost food or changes in their ideal state), it is recalled that the facility should be equipped with electronic devices or electromechanical safety and warning system.

They should be placed outside the measuring and control equipments, possible protective devices, responding to specific safety requirements that are covered by the norm of the product or suggest the common sense.

For your own safety, is highly recommended fulfilling the instructions provided above.

3.2 - MECHANICAL MOUNTING

The instrument, in case 185 x 37 mm, is designed for flush-in panel mounting.

Make a hole 150 x 31 mm, insert the instrument, fixing it with 2 screws and to apply the provided special covers.

We recommend that the gasket is mounted in order to obtain the front protection degree as declared. Avoid placing the instrument in environments with very high humidity levels or dirt that may create condensation or introduction of conductive substances into the instrument.

Ensure adequate ventilation to the instrument and avoid installation in containers that house devices which may overheat or which may cause the instrument to function at a higher temperature than the one permitted and declared.

Connect the instrument as far away as possible from sources of electromagnetic disturbances such as motors, power relays, relays, solenoid valves, etc.

3.3 - ELECTRICAL CONNECTION

Carry out the electrical wiring by connecting only one wire to each terminal, according to the following diagram, checking that the power supply is the same as that indicated on the instrument and that the load current absorption is no higher than the maximum electricity current permitted.

As the instrument is built-in equipment with permanent connection inside housing, it is not equipped with either switches or internal devices to protect against overload of current: the installation will include an overload protection and a two-phase circuit-breaker, placed as near as possible to the instrument, and located in a position that can easily be reached by the user and marked as instrument disconnecting device which interrupts the power supply to the equipment.

It is also recommended that the supply of all the electrical circuits connected to the instrument must be protect properly, using devices (ex. fuses) proportionate to the circulating currents.

It is strongly recommended that cables with proper insulation, according to the working voltages and temperatures, be used. Furthermore, the input cable of the probe has to be kept separate from line voltage wiring. If the input cable of the probe is screened, it has to be connected to the ground with only one side.

We recommend that a check should be made that the parameters are those desired and that the application functions correctly before connecting the outputs to the actuators so as to avoid malfunctioning that may cause irregularities in the plant that could cause damage to people, things or animals.

3.4 - ELECTRICAL WIRING DIAGRAM

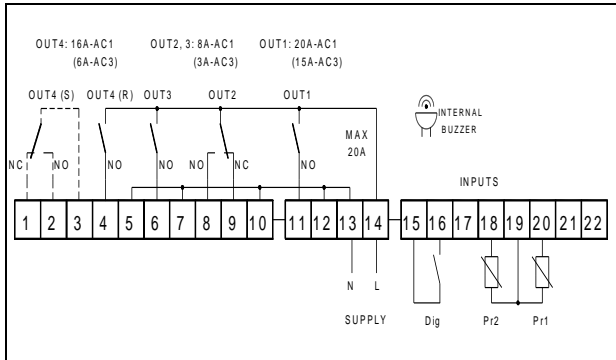

When the instrument is switched off, such values are always re-set. However, it is also possible to reset these values if the instrument is switched on by using the P key hold for 2 sec. during peak visualization. The display will show "r.Pic" and peaks memory will be reset.

4.3 - OUTPUTS CONFIGURATION

The instrument outputs can be configured in the parameters group "Out" where the relative parameters "Out1", "Out2", "Out3" and "Out4".

The outputs can be configured for the following functions:

- = **Out** - to control the compressor or however, the temperature control device
- = **dEF** - to control the defrosting device
- = **FAn** - to control the fans
- = **LIGH** - to control the light
- = **AuS** - to control the auxiliary device (see par. 4.13)
- = **ALt** - to control a silenceable alarm device through a contact that is normally open, and then closed when the alarm sounds
- = **AL** - to control an alarm that cannot be silenced through a contact that is normally open and closed when the alarm sounds.
- = **ALL** - to control an alarm with a memory function through a contact that is normally open and closed when the alarm sounds.
- = **-ALt** - to control a silenceable alarm device through a contact that is normally closed, and then open when the alarm sounds.
- = **-AL** - control an alarm that cannot be silenced through a contact that is normally closed and open when the alarm sounds.
- = **-ALL** - to control an alarm with a memory function through a contact that is normally closed and open when the alarm sounds (see par. 4.11.4).
- = **On** - Output on when the instrument is in on state. This mode can be used to control non-misting resistance on room door or other utilities
- = **OFF** - Disabled output

4 - FUNCTIONS

4.1 - MEASURING AND VISUALIZATION

All the parameters concerning measuring are contained in the group "InP".

Via the parameter "SEnS" it is possible to select the type of probes that one wishes to use and which can be: thermistores PTC KTY81-121 (Ptc) or NTC 103AT-2 (ntc).

Once the type of probe used has been selected, through the parameter "Unit", it is possible to select the temperature unit of measurement (°C or °F) and, through the parameter "dP", the resolution of the desired measurement (OFF=1°; On =0,1°). The instrument allows the measuring to be calibrated, that can be used for re-calibrating the instrument according to application needs, through the parameters "OFS1" (for the probe Pr1) and "OFS2" (for the probe Pr2).

If probe Pr2 (evaporator) is not used, set the parameter "Pr 2" = OFF.

Using the parameter "FiL", it is possible to set the time constant for the software filter for measuring the input values to be able to reduce the sensitivity to measurement disturbances (increasing the time).

Through the paragraph "diSP", it is possible to fix the normal visualisation on the display that can be the measurement of the cell probe (Pr 1), the measurement of the evaporator probe (Pr 2), the set point of active regulation (SP) or it can have the numerical display switched off (OFF).

Regardless of what is set in the parameter "diSP", it is possible to visualise all the variables in rotation by pressing the key U, the display will alternately show the code that identifies the variable (Pr 1, Pr 2) and its value.

The exit of this visualisation mode occurs automatically 15 seconds after the last pressing on the key U.

Please remember that visualisation of the probe Pr1 can be changed by the display block in defrosting function too, by using the parameter "dLo" (see par. 4.7).

4.2 - ROOM PROBE PEAK VALUES MEMORIZATION

The instrument memorizes the highest and lowest peak room probe (Pr1) measurement values.

To visualize such values simply press the UP key and release it to visualize the highest peak (blinked and signalled by led + on) or the DOWN key and release it for the lowest peak (blinked and signalled by led - on) during normal operation of the instrument.

After 5 sec. or by press the key UP or DOWN the display come back to normal mode.

4.4 - TEMPERATURE CONTROL

All the parameters concerning temperature regulation are contained in the group "rREG".

The regulation of the instrument is ON/OFF and acts on the output configured as "Out" depending on the measuring of probe Pr1, of the active Set Point "SP" (1 or 2), the intervention differential "HSEt" and the function mode "Func".

Depending on the function mode programmed on the parameter "Func" the differential is automatically considered by the regulator with positive values for a Refrigeration control ("Func"=Cool) or with negative values for a heating control ("Func"=HEAt).

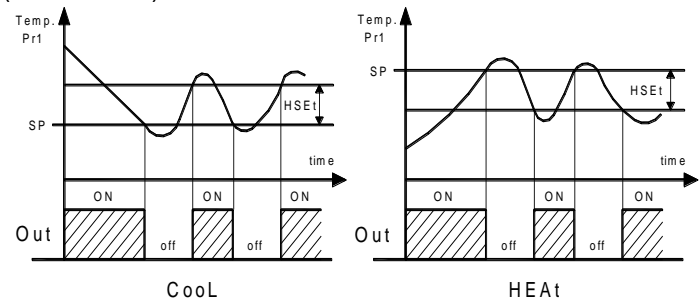

In the event of cell probe error (Pr1), it is possible to set the instrument so that that the output "Out" continues to work in cycles according to the times programmed in the parameter "tonE" (activation time) and "toFE" (deactivation time).

If an error occurs on the probe Pr1 the instrument activates the output for the time "tonE", then deactivates it for the time "toFE" and so on whilst the error remains.

Programming "tonE" = OFF lthe output in probe error condition will remain switched off.

Programming instead "tonE" to any value and "toFE" = OFF the output in probe error condition will remain switched on.

Remember that the temperature regulation function can be conditioned by the "Continuous Cycle", "Compressor Protection", "Minimum compressor function time", "Delay compressor start up after defrosting" and "inhibition of compressor close to defrosting" functions described below.

4.5 - CONTINUOUS CYCLE FUNCTION

The instrument has a continuous cycle function by which it is possible to maintain the configured output configured as "out" always active for the time set in parameter "tCC" (in the group "REG") regardless of the temperature control command.

The function can be used for example, when rapid lowering of the product temperature is required after the refrigerator loading phase.

During the continuous cycle, the defrosting is inhibited and the temperature alarms are disabled during the entire cycle and also later for the time set in parameter "dALc" (see par. 4.11.1).

Starting up a continuous cycle can only be done by a manual command using the **UP/CONT.CYCLES** key or via the digital input ("diF"=3) if suitably programmed (see par. 4.12).

The continuous cycle in progress is shown on the display with the indication **CC** and can be stopped by a further action on the key or digital input (as for activation).

The continuous cycle function cannot be activated during defrosting and with "tCC" = OFF.

4.6 - COMPRESSOR PROTECTION FUNCTION AND DELAY AT POWER-ON

All the parameters concerning the compressor protection functions and the delay at power on are contained in the group "PrC".

The function "Compressor Protection" carried out by the machine aims to avoid close start ups of the compressor controlled by the instrument in cooling applications.

This function foresees a time control on the switching on of the "Out" output associated with the temperature regulation request.

The protection consists of preventing the output being switched on during the time set in the parameter "PtC" and counted depending on what has been programmed in the parameter "PSC", and therefore that any activation occurs only after the "PtC" time has finished.

If during the power on delay phase, the regulator request should disappear, due to an inhibition caused by the compressor protection function, the foreseen start up of the output is naturally cancelled.

Using the parameter "PSC", it is possible to set the type of compressor protection and therefore from when the inhibition time "PtC" must start.

The parameter "PSC" can be set as:

= 1 : Power on delay

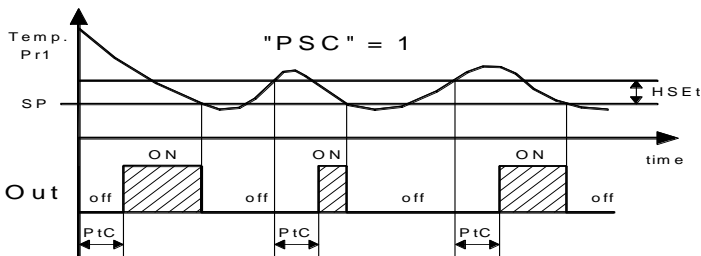

= 2 : Delay after power off

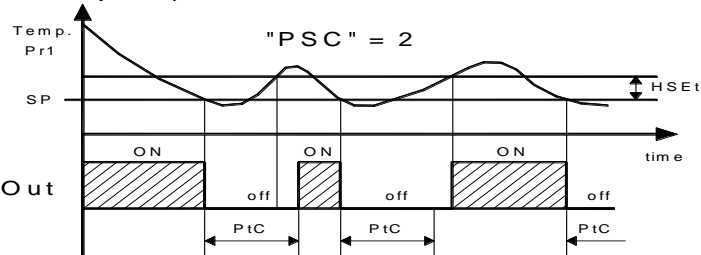

= 3 : Delay between power on phases.

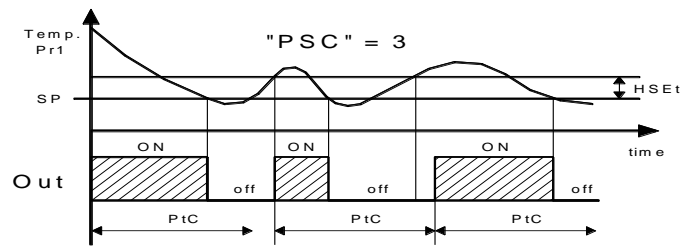

Through the parameter "LCt" it is also possible to set the minimum activation time of the output to avoid switching on of the compressor that is too short.

During the power on delay phases of the OUT output by inhibiting the function "Compressor Protection" or delay of power off caused by the minimum function time "LCt", the led OUT flashes.

It is also possible to prevent activation of all the outputs after the instrument is turned on, for the time set in the parameter "od".

During the power on delay phase, the display shows the indication **od**, alternating with the normal programmed visualisation.

All timer functions are disabled by set relative parameters = OFF.

4.7 - DEFROST CONTROL

All the parameters concerning the defrosting control that acts on the outputs configured as "Out" and "dEF", are contained in the group "dEF".

The type of defrosting that the instrument must carry out is set by the parameter "dtyP" that can be programmed:

= **EL** - WITH ELECTRICAL HEATING or BY STOPPING COMPRESSOR (during defrosting, the output "Out" is deactivated while the output "dEF" is enabled)

= **in** - WITH HOT GAS or INVERSION OF CYCLE (during defrosting the outputs "Out" and "dEF" are enabled)

The automatic defrosting can take place at intervals.

Defrosting at intervals is possible by setting the time that runs between the two next automatic defrostings in the parameter "dint".

Counting this interval is set through the parameter "dCt" that can be programmed:

= **rt** - counts the total function time (instrument on)

= **ct** - counts only the compressor function time (output OUT switched on)

= **cs** - the instrument carries out a defrosting cycle at each compressor stop (i.e. at each deactivation of the output OUT).

If this option is used, set "dint"=OFF.

The automatic defrosting cycle can be ended by time or, if an evaporator probe is used (Pr2), when a temperature is reached. If the evaporator probe is not used (par. "Pr 2" = OFF) the duration cycle is set by the parameter "dEFE".

If instead the evaporator probe is used (parameter "Pr 2" = on) the defrost end when the temperature measured by the probe exceeds the temperature set in the parameter "tEdF".

If this temperature is not reached in the time set in the parameter "dEFE", defrosting is interrupted.

In order to avoid pointless defrosting the parameter. "tSdF" is foreseen that sets the enablement temperature for defrosting. If the temperature measured by the probe is higher than the one set in the parameter "tSdF" and in the parameter "tEdF" the defrosting is inhibited.

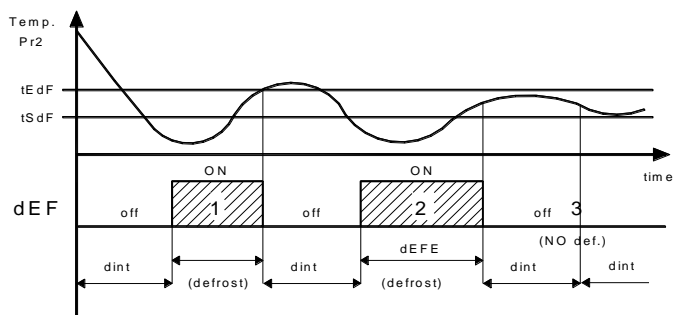

Examples: defrosting 1 ends due to reaching of temperature “ t_{EdF} ”, defrosting 2 ends at the end of the “ $dEFE$ ” time as the temperature “ t_{EdF} ” is not reached, defrosting 3 does not take place as the temperature is higher than “ t_{SdF} ”.

At the end of defrosting, it is possible to delay the new start up of the compressor (output “Out”) at the time set in parameter “ $tdCO$ ” to allow the evaporator to drain.

During this delay, the led Def flashes to indicate the draining state.

If one wishes to set a defrosting cycle every time the instrument is switched on (as long as the conditions set in the parameters “ t_{SdF} ” and “ t_{EdF} ” apply) programme the parameter “ $SdEF$ ” = yES.

This allows the evaporator to be permanently defrosted, even when frequent interruptions to power supply occur that may cause the cancellation of the various defrosting cycles.

During the defrosting, it may occur that the temperature measured by the cell probe (Pr1) increases excessively (this obviously depends on the position of the probe Pr1 compared to the evaporator).

In the event that one does not wish this increase to be visualised by the instrument, it is possible to use the functions in the parameter “ dLo ” (Block display during defrosting) and “ $Etdu$ ” (Differential unblocking of display after defrosting).

The parameter “ dLo ” = On allows the temperature Pr1 visualisation to be blocked on the last reading during a whole defrosting cycle and until the temperature does not return under the value [SP] + “ $Etdu$ ” after defrosting has finished (or the time set in the parameter “ $dALd$ ” contained in the block “ AL ”).

With “ dLo ” = Lb, this allows visualisation of the writing **dEF** during defrosting and at the end of defrosting the writing **PdEF** up to when the temperature Pr1 does not return below the value [SP] + “ $Etdu$ ” (or the time set on the parameter “ $dALd$ ” contained in the block “ AL ”).

Alternatively with the “ dLo ” = OFF, during defrosting, the instrument will continue to visualise the temperature measured by the probe Pr1.

Note that during defrosting, the temperature alarms are disabled during the whole cycle and also afterwards for the time set in the parameter “ $dALd$ ” (see par. 4.11.1).

4.8 - MANUAL DEFROST

To start up a manual defrosting cycle, press the key **DEFROST** and keep it pressed for about 5 seconds after which, if the conditions are correct, the led DEF will light up and the instrument will carry out a defrosting cycle.

The start up or switch off commands of a defrosting cycle can also be given by the digital input that are correctly programmed (see par. 4.12).

4.9 - EVAPORATOR FANS CONTROL

All the parameters concerning fan control are contained in the group “**FAN**”.

The control of the fans on the output configured as “**FAN**” depending on determined control statuses of the instrument and the temperature measured by the probe Pr2.

In the case that the probe Pr2 is not used (parameter “Pr 2” = OFF) or in error (E2 o -E2), the output FAN is activated only depending on the parameters “**FCOF**” and “**FEdF**”.

The parameter “**FCOF**” decides whether the fans must always be switched on independently of the compressor status (“**FCOF**=On) or be switched off together with the compressor (“**FCOF**=OFF).

The parameter “**FEdF**” instead decides whether the fans must always be switched on independently of the defrosting status (“**FEdF**=On) or switched off during defrosting (“**FEdF**=OFF).

In this latter case, it is possible to delay the start up of the fans even after the end of the defrosting of the time set in the parameter “**Fd**”.

When the probe Pr2 is used (par. “Pr 2” = on) the fans, as well as being conditioned by the parameters “**FCOF**” and “**FEdF**”, are also conditioned by the temperature control.

It is possible to set the disablement of the fans when the temperature measured by the probe Pr2 is higher than the one set in the parameter “**FLt**” (temperature too hot) or when it is lower than the one set in the parameter “**Fct**” (temperature too cold).

The relative differential that can be set in parameter “**df**” is also associated with these parameters.

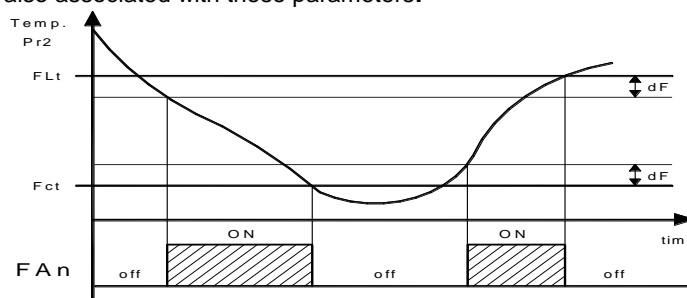

4.10 - ROOM LIGHT CONTROL

The control of the light on the output configured as “**LIGHT**” by **LIGHT** key or by the digital input that are correctly programmed at par. “ diF ” (see par. 4.12).

The **LIGHT** output it's always actionable also when the controller is in OFF mode (standby).

If the **LIGHT** output is activated by **LIGHT** key the digital input it doesn't have effect (the output has to be switch off by the key).

4.11 - ALARM FUNCTIONS

All the parameters concerning the alarm functions are contained in group “**AL**”.

The alarm functions of the instrument work on the internal buzzer and on the output desired, if configured by the parameters “**Out1**”, “**Out2**”, “**Out3**” or “**Out4**”, depending on what is set on the said parameters.

The possible selections of these parameters for the alarm signalling function are:

= **ALt** - when one wants the output to be activated in alarm and can be disabled (alarm silencing) manually by pressing any key of the instrument (typical application for sound signal).

= **AL** - when one wants the output to be activated in alarm status but cannot be disabled manually and are therefore only disabled when the alarm status ceases (typical application for a light signal).

= **ALL** - when one wants the output to be activated in alarm status and that they remain activated even when the alarm has ceased (see par.4.11.4) Disablement (recognition of memorised alarm) can only be carried out manually by pressing any key when the alarm has ended (typical application for light signal).

= **-ALt** - when one wants the function described as **ALt** but with an inverse function (output activated in normal condition and disabled in alarm status).

= **-AL** - when one wants the function described as **AL** but with inverse logic (output activated in normal conditions and disabled in alarm status).

= **-ALL** - when one wants the function described as **ALL** but with inverse working logic (output activated in normal conditions and disabled in alarm status).

When no alarms are present, the green LED OK is lit.
 Any active alarm is shown on the instrument display with the lighting up of the AL led and the switching off of the led OK.
 Any silenced or memorised alarm status is shown by the AL led flashing .

The alarm conditions of the instrument are:

- Probe errors "E1", "-E1", "E2", "-E2"
- temperature alarms "HI" and "LO"
- External alarms "AL"
- Open door alarm "AP"

4.11.1 - TEMPERATURE ALARMS

The temperature alarms work according to the probe Pr1 measurements, the type of alarm set in the parameter "Aty" the alarm thresholds set in parameters "HAL" (maximum alarm) and "LAL" (minimum alarm) and the relative differential "dAL".

Through the parameter "Aty" it is possible to set the alarm thresholds "HAL" and "LAL" which must be considered as absolute ("Aty"=Ab) or relative to the active Set Point ("Aty"=dE).

Using some parameters it is also possible to delay the enablement and the intervention of these alarms.

These parameters are:

"PAL" - is the temperature alarm exclusion time on switching on the instrument if the instrument is in alarm status when it is switched on.

"dALd" - is the temperature alarm exclusion time at the end of defrosting (and , if programmed, at the end of draining)

"dALc" - is the temperature alarm exclusion time at the end of a continuous cycle.

"ALd" - is the temperature alarm delay activation time

The temperature alarm is enabled at the end of exclusion time and is enabled after the "ALd" time when the temperature measured by the probe Pr1 exceeds or goes below the respective maximum and minimum alarm thresholds.

The alarm thresholds will be the same as those set on the parameters "HAL" and "LAL" if the alarms are absolute ("Aty"=Ab)

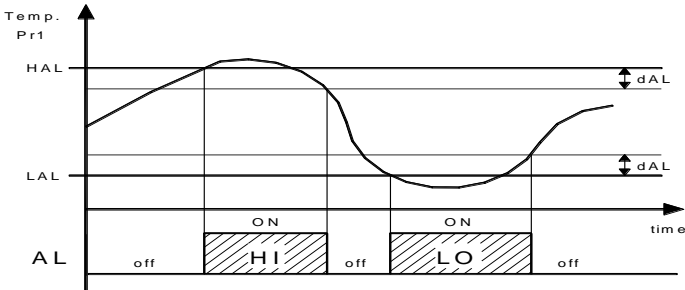

or will be the values ["SP"+"HAL"] and ["SP"-"LAL"] if the alarms are relative ("Aty"=dE).

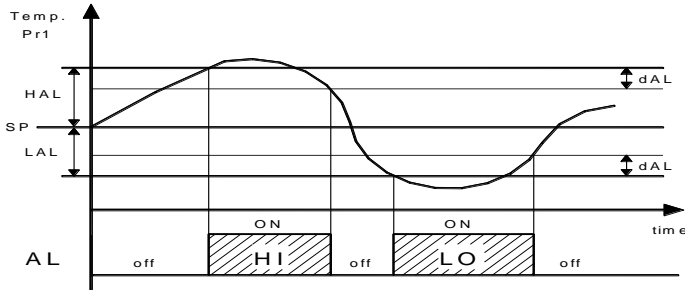

The maximum and minimum temperature alarms can be disabled by setting the relative parameters "HAL" and "LAL" = OFF.

At the same time as the signalling of the configured alarm (buzzer and output), the instrument signals the alarm by turning on the led light AL, switching off the LED OK, turning on the led - in case of minimum alarm or the led + for maximum alarm, and visualises on the display:

- Alternately HI and the set variable in parameter "diSP" for maximum alarm

- Alternately LO and the set variable in parameter "diSP" for the minimum alarm

4.11.2 - EXTERNAL ALARM

The instrument can signal an external alarm by activating the digital input with the function programmed as "diF" = 4 or 10 (see par. 4.12).

At the same time as the signalling of the configured alarm (buzzer and output), the instrument signals the alarm by turning on the led AL, turning off the led OK and visualising AL and the variable set in parameter "diSP" alternately on the display.

4.11.3 - OPEN DOOR ALARM

The instrument can signal an open door alarm by activating the digital input with the function programmed as "diF" = 5, 6, 7 (see par. 4.12).

When the digital input is activated and after the delay programmed in parameter "oAd", the instrument signals the alarm via the activation of the configured devices (buzzer and output), the turning on of the led AL, the turning off of the led OK and AP and the variable set in parameter "diSP" are visualised alternately on the display.

If the function of the digital input foresees the fan or the fan and compressor switch off at the alarm activation the load will be reactivated even if the digital input is active.

4.11.4 - ALARM MEMORY

The instrument offers the possibility of arranging the alarm memory function via the parameter "tAL".

If "tAL" = no, the instrument cancels the alarm signal when the alarm status ends, if instead it is programmed as "yES", the led AL flashes even when the alarm status has ended to indicate that there has been an alarm.

If the memorised alarm is for temperature, it also keeps the led - flashing to show a minimum alarm and + to show a maximum alarm.

To cancel the alarm memory signal, press any key.

It must be remembered that if an output function is desired (or the buzzer) with an alarm memory (=ALL or =-ALL) it is necessary to set the parameter "tAL" = yES.

4.12 - DIGITAL INPUT

All the parameters concerning the digital input functions are contained in the group "din".

The digital input present on the instrument accepts contacts free of voltage, the function carried out is defined by the parameter "diF" and the action can be delayed for the time set in parameter "did".

The parameter "diF" can be configured for the following functions:

- = 0 - Digital input not active
- = 1 - defrosting commencement command with contact normally open: on closing the input (and after the "did" time) a defrosting cycle is activated.
- = 2 - defrosting end command with contact normally open: on closing the input (and after the "did" time) a defrosting cycle is ended if in progress or defrosting is inhibited.
- = 3 - continuous cycle activation command with contact normally open: on closing the input (and after the "did" time) a continuous cycle is started up as described in the paragraph on the continuous cycle function.
- = 4 - External alarm signal with contact normally open: on closing the input (and after the "did" time) the alarm is activated and the instrument visualises AL and the variable set in parameter "diSP" alternately on the display.
- = 5 - Cell door opening with light on with contact normally open: on closing the input (and after the "did" time) the light is switch on and the instrument visualises AP and the variable set in parameter "diSP" alternately on the display. With this function mode, the action of the digital input also activates the time that can be set in parameter "oAd" after which the alarm is activated to signal that the door has been left open. At the deactivation of digital input the light is switch off.

= **6** - Cell door opening with light on and fan block with contact normally open: on closing the input (and after the "did" time) the light is switch on, the fans are stopped and the instrument visualises **AP** and the variable set in parameter "diSP" alternately on the display. With this function mode, the action of the digital input also activates the time that can be set in parameter "oAd" after which the alarm is activated to signal that the door has been left open. At the deactivation of digital input the light is switch off. At the alarm activation the fan will be reactivated even if the digital input is active.

= **7** - Cell door opening with light on, compressor block and fan block with contact normally open: similar to "diF" = 6 but with fan and compressor block.

= **8** - Remote control of auxiliary output AUX with contact normally open: on closing the input (and after the "did" time) the auxiliary output is activated as described in the "FOA" = 2 function mode of the auxiliary output.

= **9** - Selecting the active set point with contact normally open: on closing the input (and after the "did" time) the temperature regulation set point "SP 2" is activated. When instead the input is open the set point "SP 1" is active (see selecting active set point)

= **10** - Signalling of external alarm with disablement of all the control outputs with contact normally open: on closing the input (and after the "did" time) all the control outputs are disabled, the alarm is activated and the instrument visualises **AL** and the variable set in parameter "diSP" alternately on the display.

= **11** - Switching on/switching off (Stand-by) of instrument with contact normally open: on closing the input (and after the "did" time) the instrument is switched on while it is placed in Stand-by when opened.

= **-1, -2, -3-11** - Similar to the previous but with function logic reversed (contact normally closed)

4.13 - AUXILIARY OUTPUT

All the parameters concerning the auxiliary output functions are contained in the group "**AuS**".

The auxiliary output can be configured to operate on any of the outputs by programming the parameter of the desired output = AuS.

The function carried out is defined by the parameter "**FOA**" and the function is conditioned by the time set in parameter "**tuA**".

The parameter "**FOA**" can be configured for the following functions:

= **0** - Auxiliary output not active

= **1** - Regulation output delayed with contact normally open: the auxiliary output is activated with delay that can be set on the parameter "tuA" compared to the output configured as Out. The output is then turned off at the same time as the OUT output is disabled. This function mode can be used as a command for a second compressor or for all other working utilities according to the same OUT output conditions, but which must be delayed after the start up of the compressor to avoid excess electricity absorption.

= **2** - Activation by front key (U or DOWN/AUX) or by digital input with contact normally open: the output is activated by pressing the keys U or DOWN/AUX suitably configured ("USrb" or "Fbd" = 1) or via activation of the digital input if suitably configured ("diF"=8). These commands have a bi-stable function, Which means that when first pressed, the output key is activated while the second is disabled. In this mode, the AUX output can be turned off automatically after a certain time that can be set on the parameter "tuA". With "tuA" = OFF the output is activated and deactivated only manually, using the front key (U or DOWN/AUX) or via the digital input. Differently, the output, once activated, is turned off automatically after the set time. This function can be used, for example, as a cell light command, for non-misting resistance or other utilities .

4.14 - FUNCTIONING OF KEYS "U" AND "DOWN/AUX"

Two of the instrument keys, in addition to their normal functions, can be configured to operate other commands.

The U key function can be defined by the parameter "**USrb**" while the DOWN/AUX key function can be defined by the parameter "**Fbd**" both contained in the group "**PAAn**".

Both the parameters have the same possibilities and can be configured for the following functions:

= **0** - The key carries out no function.

= **1** - Pressing the key for at least 1 second, it is possible to enable/disable the auxiliary output if configured ("FOA"=2).

= **2** - Pressing the key for at least 1 second, it is possible to select one of the 2 memorised set point in rotation. Once selection has been made, the display will flash the active set point code for about 1 sec. (SP 1or SP 2).

4.15 - PARAMETERS CONFIGURATION BY "KEY USB"

The instrument is equipped with a connector that allows the transfer from and toward the instrument of the functioning parameters through the device **OSAKA KEY USB** with **5 poles** connector.

This device it's mainly useable for the serial programming of the instruments which need to have the same parameters configuration or to keep a copy of the programming of an instrument and allow its rapid retransmission.

To use the device KEY USB it's necessary that the device or instrument are being supplied.

Instrument supplied and device not supplied

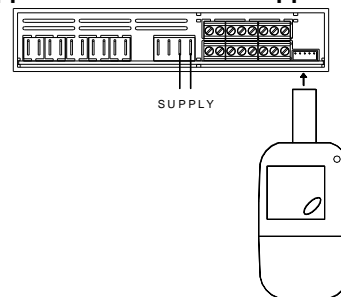

Instrument supplied from the device

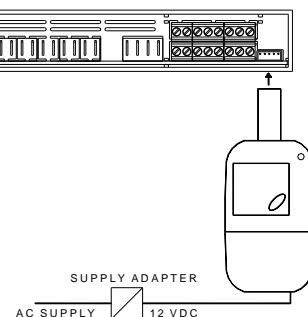

To transfer the configuration of an instrument into the device (**UPLOAD**) it is necessary to proceed in the following way:

- 1) position both dip switch of KEY USB in the **OFF** mode.
- 2) connect the device to the instrument COMPACT plugging the special connector.
- 3) verify that the instrument or the device are supplied
- 4) observe the indication led on the device KEY USB: if it results green this means that a configuration is already loaded on the device while if it results green blinking or red blinking this means that it has not been loaded any valid configuration on the device .
- 5) press the button placed on the device.
- 6) observe the indication led : after having pressed the button, the led becomes red and therefore, at the end of the data transfer, it becomes green.
- 7) now it is possible to disconnect the device.

To transfer the configuration loaded on the device onto an instrument of the same family (**DOWNLOAD**), it is necessary to proceed in the following way:

- 1) position both dip switch of KEY USB in the **ON** mode.
- 2) connect the device to an instrument COMPACT having the same features of the one from which has been downloaded the desired configuration, plugging the special connector.

- 3) verify that the instrument or the device are supplied
- 4) observe the indication led on the device KEY USB: it has to result green, because if the led results green blinking or red blinking, this means that on the device it has not been downloaded any valid configuration and therefore it's useless to continue.
- 5) if the les results green, press the button placed on the device.
- 6) observe the indication led : after having pressed the button, the led becomes red and therefore, at the end of the data transfer, it becomes green.
- 7) now it is possible to disconnect the device.

For additional info, please have a look at the KEY USB instruction manual.

5 - PROGRAMMABLE PARAMETERS TABLE

Here below is a description of all the parameters available on the instrument. Some of them may not be present, either due to the fact they depend on the type of instrument or because they are automatically disabled as unnecessary.

Group ¹SP (parameters relative to Set Point)

| Par. | Description | Range | Def. |
|------|-------------------------------|-------------|-------|
| 1 | SPAt Active Set point | 1 ÷ 2 | 1 |
| 2 | SP1 Set Point 1 | SPLL ÷ SPHL | 0.0 |
| 3 | SP2 Set Point 2 | SPLL ÷ SPHL | 0.0 |
| 4 | SPLL Minimum Set Point | -58 ÷ SPHL | -50.0 |
| 5 | SPHL Maximum Set Point | SPLL ÷ 302 | 100.0 |

Group ¹InP (parameters relative to measuring inputs)

| Par. | Description | Range | Def. |
|------|---|----------------------|------|
| 6 | SEnS Probes Type | Ptc - ntc | Ptc |
| 7 | OFS1 Pr1 Probe (cell) Calibration | -30 ÷ 30 °C/°F | 0.0 |
| 8 | OFS2 Pr2 Probe (evaporator) Calibration | -30 ÷ 30 °C/°F | 0.0 |
| 9 | Pr 2 Pr2 Probe Presence (evaporator) | On - OFF | On |
| 10 | Unit Unit of measurement | °C - °F | °C |
| 11 | dP Decimal point | On - OFF | On |
| 12 | FiL Measurement filter | OFF ÷ 20.0 sec | 2.0 |
| 13 | diSP Variable visualized normally on display: OFF=Display off Pr1= measurement probe Pr1 Pr2= measurement probe Pr2 SP= Active Set Point | OFF - Pr1 - Pr2 - SP | Pr1 |

Group ¹REG (parameters relative to temperature control)

| Par. | Description | Range | Def. |
|------|---|---------------------|-------|
| 14 | HSEt Differential | 0 ÷ 30 °C/°F | 2.0 |
| 15 | tonE Activation time output OUT for probe Pr1 broken | OFF ÷ 99.59 min.sec | OFF |
| 16 | toFE Deactivation time output OUT for probe Pr1 broken | OFF ÷ 99.59 min.sec | OFF |
| 17 | Func Function mode output OUT | HEAt - CoolL | CoolL |
| 18 | tCC Continuous cycle Time | OFF ÷ 99.59 hrs.min | OFF |

Group ¹dEF (parameters relative to defrosting control)

| Par. | Description | Range | Def. |
|------|---|----------------------|-------|
| 19 | dtYP Defrosting Type: EL = electrical in = hot gas/reverse cycle | EL - in | EL |
| 20 | dint Defrosting interval | OFF ÷ 99.59 hrs.min | 6.00 |
| 21 | dEFE Max. lenght of defrost cycle | 0.01 ÷ 99.59 min.sec | 30.00 |
| 22 | tEdF Defrost stop temperature | - 58 ÷ 302 °C/°F | 8.0 |
| 23 | tSdF Defrost enable temperature | - 58 ÷ 302 °C/°F | 2.0 |
| 24 | dCt Defrosting intervals Counting mode: rt = real time ct = On OUT time cS = defrost every off OUT | rt - ct - cS | rt |
| 25 | tdCO Compressor delay after defrost (drainage time) | OFF ÷ 99.59 min.sec | OFF |
| 26 | SdEF Defrost at power on | no - yES | no |
| 27 | dLo Defrost display Lock OFF= display free On= Lock on temperature Pr1 before defrost Lb= Lock on label "dEF" (during defrosting) and "PdEF" (during post-defrosting) | On - OFF - Lb | OFF |
| 28 | Etdu Differential display unlock after defrost | 0 ÷ 30 °C/°F | 2.0 |

Group ¹FAn (parameters relative to evaporator fan control)

| Par. | Description | Range | Def. |
|------|--|---------------------|-------|
| 29 | FCOF Fan status with compressor off | On - OFF | On |
| 30 | FEdF Fan status during defrost | On - OFF | OFF |
| 31 | FLt High temperature fan off | - 58 ÷ 302 °C/°F | 2.0 |
| 32 | Fct Low temperature fan off | - 58 ÷ 302 °C/°F | -50.0 |
| 33 | dF Differential fan control | 0 ÷ 30 °C/°F | 2.0 |
| 34 | Fd Fan delay after defrost | OFF ÷ 99.59 min.sec | OFF |

Group ¹PrC (parameters relative to compressor protection and power on delay)

| Par. | Description | Range | Def. |
|------|--|---------------------|------|
| 35 | PSC Type of compressor protection: 1= delay at switch on 2= delay after switch off 3= delay between starts | 1 - 2 - 3 | 1 |
| 36 | PtC Compressor protection time | OFF ÷ 99.59 min.sec | OFF |
| 37 | LtC Minimum compressor function time | OFF ÷ 99.59 min.sec | OFF |
| 38 | od Delay at power on | OFF ÷ 99.59 min.sec | OFF |

Group ¹AL (parameters relative to alarms)

| Par. | Description | Range | Def. |
|------|--|---------|------|
| 39 | Aty Temperature alarms Type: Ab = Absolute dE =Relative to Set | Ab - dE | Ab |

| | | | | |
|----|-------------|---|------------------------|------|
| 40 | HAL | High temperature Alarm threshold | OFF / - 58 ÷ 302 °C/°F | OFF |
| 41 | LAL | Low temperature Alarm threshold | OFF / - 58 ÷ 302 °C/°F | OFF |
| 42 | dAL | Temperature Alarms Differential | 0 ÷ 30 °C/°F | 2.0 |
| 43 | ALd | Temperature Alarms delay | OFF ÷ 99.59 min.sec | OFF |
| 44 | tAL | Alarm memory | no - yES | no |
| 45 | PAL | Temperature Alarms delay at power on | OFF ÷ 99.59 hrs.min | 2.00 |
| 46 | dALd | Temperature Alarms delay and unlock display delay after defrost | OFF ÷ 99.59 hrs.min | 1.00 |
| 47 | dALc | Temperature alarms delay after continuous cycle | OFF ÷ 99.59 hrs.min | OFF |
| 48 | oAd | Alarm delay with open door | OFF ÷ 99.59 min.sec | OFF |

Group ¹din (parameters relative to digital input)

| Par. | Description | Range | Def. |
|------|--|--|------|
| 49 | diF Function and function logic of digital input: 0 = No function 1= Start defrost 2= End defrost 3= Continuous cycle 4= External alarm 5= Door open with light on 6= Door open with light on and fan block 7= Door open with light on and fan and compressor block 8= Auxiliary output command 9= Selection of active Set Point 10= External alarm with deactivation of control outputs 11= Switch on/Switch off (Stand-by) | -11 / -10 / -9 / -8 / -7 / -6 / -5 / -4 / -3 / -2 / -1 / 0 / 1 / 2 / 3 / 4 / 5 / 6 / 7 / 8 / 9 / 10 / 11 | 0 |
| 50 | did Delay in acquiring digital input | OFF ÷ 99.59 min.sec | OFF |

Group ¹AuS (parameters relative to auxiliary output)

| Par. | Description | Range | Def. |
|------|--|---------------------|------|
| 51 | FOA Function mode auxiliary output: 0= No Function 1= regulation output delayed 2= manual activation by key or digital input. | 0 / 1 / 2 | 0 |
| 52 | tuA Time relative to auxiliary output | OFF ÷ 99.59 min.sec | OFF |

Group ¹Out (parameters relative to configuration of outputs)

| Par. | Description | Range | Def. |
|------|--|--|------|
| 53 | Out1 Configuration of output function OUT1: OFF= No function Out= Temperature control (compressor) dEF= defrosting FAn= fans AuS= Auxiliary ALt= Silenceable alarm | OFF/ Out / dEF/ Fan / LIGH / AuS / ALt / AL / ALL / -ALt / -AL / -ALL / On | Out |

| | | AL= Alarm not silenceable ALL= memorised alarm On= On state | | |
|----|-------------|---|--|------|
| 54 | Out2 | Configuration of output function OUT2: see "Out1" | OFF/ Out / dEF/ Fan / LIGH / AuS / ALt / AL / ALL / -ALt / -AL / -ALL / On | dEF |
| 55 | Out3 | Configuration of output function OUT3: see "Out1" | OFF/ Out / dEF/ Fan / LIGH / AuS / ALt / AL / ALL / -ALt / -AL / -ALL / On | FAn |
| 56 | Out4 | Configuration of output function OUT4: see "Out1" | OFF/ Out / dEF/ Fan / LIGH / AuS / ALt / AL / ALL / -ALt / -AL / -ALL / On | LIGH |

Group ¹PAn (parameters relative to configuration of the keyboard)

| Par. | Description | Range | Def. |
|------|--|-------------|------|
| 57 | Fbd Function mode key DOWN/AUX: OFF= No function 1= Auxiliary output command 2= Selection of active Set Point | OFF / 1 / 2 | OFF |
| 58 | USrb Function mode key U: see "Fbd" | OFF / 1 / 2 | OFF |
| 59 | PASS Access Password to parameter functions | OFF ÷ 9999 | OFF |

6 - PROBLEMS, MAINTENANCE AND GUARANTEE

6.1 - SIGNALLING

Error Signalling:

| Error | Reason | Action |
|-------------------------|--|---|
| E1 -E1 | The probe Pr1 may be interrupted or in short circuit, or may measure a value outside the range allowed | Check the correct connection of the probe with the instrument and check the probe works correctly |
| E2 -E2 | The probe Pr2 may be interrupted or in short circuit, or may measure a value outside the range allowed | |
| EEPr | Internal memory error | Check and if necessary re-programme the parameters function. |

In Cell probe error status, the output OUT behaves as set by the parameters "tonE" and "toFE".

Other Signalling:

| Message | Reason |
|-------------|---|
| od | Delay in switching on in progress |
| dEF | Defrosting in progress with "dLo"=Lb |
| PdEF | Post-defrosting in progress with "dLo"=Lb |
| CC | Continuous cycle in progress |
| HI | Maximum temperature alarm in progress |
| LO | Minimum temperature alarm in progress |
| AL | Digital input alarm in progress |
| AP | Door open |

6.2 - CLEANING

We recommend cleaning of the instrument with a slightly wet cloth using water and not abrasive cleaners or solvents which may damage the instrument.

6.3 - GUARANTEE AND REPAIRS

This device has a guarantee in form of repair or replacement by manufacturing defects in materials of 12 months from the date of purchase.

OSAKA SOLUTIONS automatically void this guarantee and is not liable for any damages deriving from:

- Use, installation, or use and handling undue, others than those described above and, in particular, differs from the safety requirements established by the regulations.
- Use in applications, machines or electrical panels that do not provide adequate protection against liquids, dust, grease and electric shocks to the installation conditions made.
- The inexperienced handling, and / or alteration of the product.
- The installation / use in applications, machines or electrical panels do not comply with the valid norm.

In case of defective product under warranty or out of that period, it should contact the post sales service to perform the necessary steps. Request document repair "RMA" (by mail or fax) and complete it, is necessary send the RMA and the device to SAT OSAKA by method prepaid.

7.3 - MECHANICAL DIMENSIONS, PANEL CUT-OUT AND MOUNTING [mm]

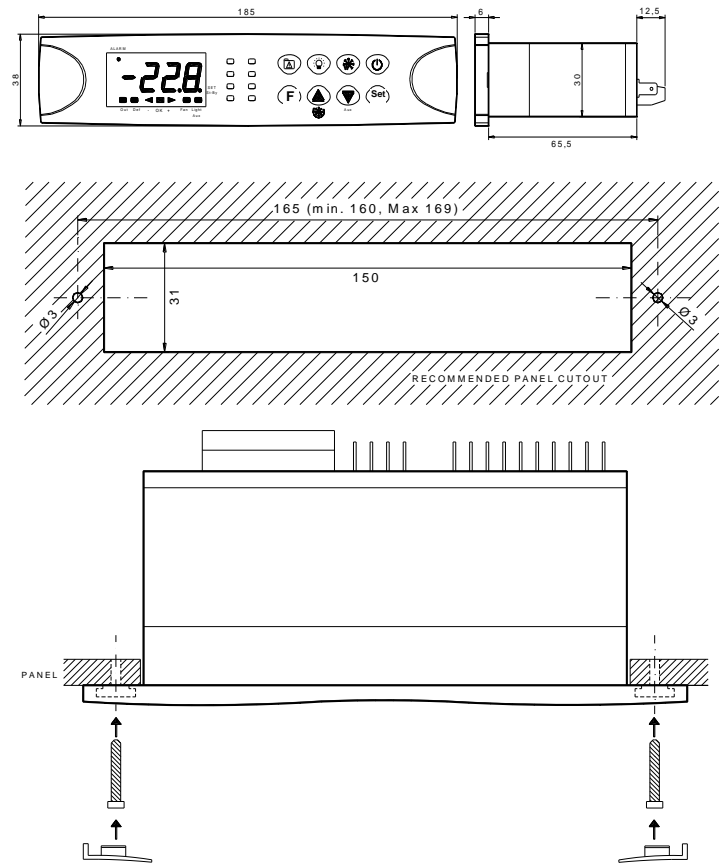

7.4 - FUNCTIONAL FEATURES

Temperature Control: ON/OFF mode

Defrost control: interval cycles by Electric Heating or hot-gas / reverse cycle

Measurement range: PTC: -50...150 °C / -58 ... 302 °F;
NTC: -50...109 °C / -58...228 °F

Display resolution: 1 ° or 0,1°

Overall accuracy: +/- (0,5 % fs + 1 digit)

Sampling rate: 130 ms.

Display: 4 Digit Red h 12 mm

Compliance: ECC directive EMC 89/336 (EN 61326), ECC directive LV 73/23 and 93/68 (EN 61010-1)

7.5 – INSTRUMENT ORDERING CODE

COMPACT 3R / 4R

3R – 3 relay

4R – 4 relay

7 - TECHNICAL DATA

7.1 - ELECTRICAL DATA

Power supply: 100..240 VAC +/- 10%

Frequency AC: 50/60 Hz

Power consumption: 5 VA approx.

Input/s: 2 inputs for temperature probes: PTC (KTY 81-121, 990 Ω @ 25 °C) or NTC (103AT-2, 10KΩ @ 25 °C); 1 digital input for free voltage contacts

Output/s: up to 4 relay outputs.

OUT1= SPST-NO (20A-AC1, 15A-AC3 /250VAC, 2HP 250VAC, 1 HP 125VAC

OUT2= SPDT (8A-AC1, 3A-AC3 250 VAC, 1/2HP 250 VAC, 1/3 HP 125 VAC).

OUT3= SPST-NO (8A-AC1, 3A-AC3 250 VAC, 1/2HP 250 VAC, 1/3 HP 125 VAC).

OUT4= SPST-NO (R) or SPDT (S) (16A-AC1, 6A-AC3 250 VAC, 1HP 250VAC, 1/2HP 125 VAC)

20 A Max. for common power supply (pin. 13, 14)

Electrical life for relay outputs: OUT1,2,3 = 100000 op. ; OUT4 = 50000 op. ; (om. VDE)

Installation category: II

Measurement category: I

Protection class against electric shock: Class II for Front panel

Insulation: Reinforced insulation between the low voltage part (supply and relay outputs) and front panel; Reinforced insulation between the low voltage section (supply and relay outputs) and the extra low voltage section (inputs); Reinforced between supply and OUT 4 relay output (S).

7.2 - MECHANICAL DATA

Housing: Self-extinguishing plastic, UL 94 V0

Dimensions: 38 x 185 mm, depth 78 mm

Weight: 240 g approx.

Mounting: Flush in panel in 31 x 150 mm hole

Connections: Faston 6,3 mm (Power supply and outputs) and 2,5 mm² screw terminals block (inputs)

Degree of front panel protection : IP 65 mounted in panel with gasket

Pollution situation: 2

Operating temperature: 0 ... 50 °C

Operating humidity: 30 ... 95 RH% without condensation

Storage temperature: -10 ... +60 °C

Examples of standards defrost

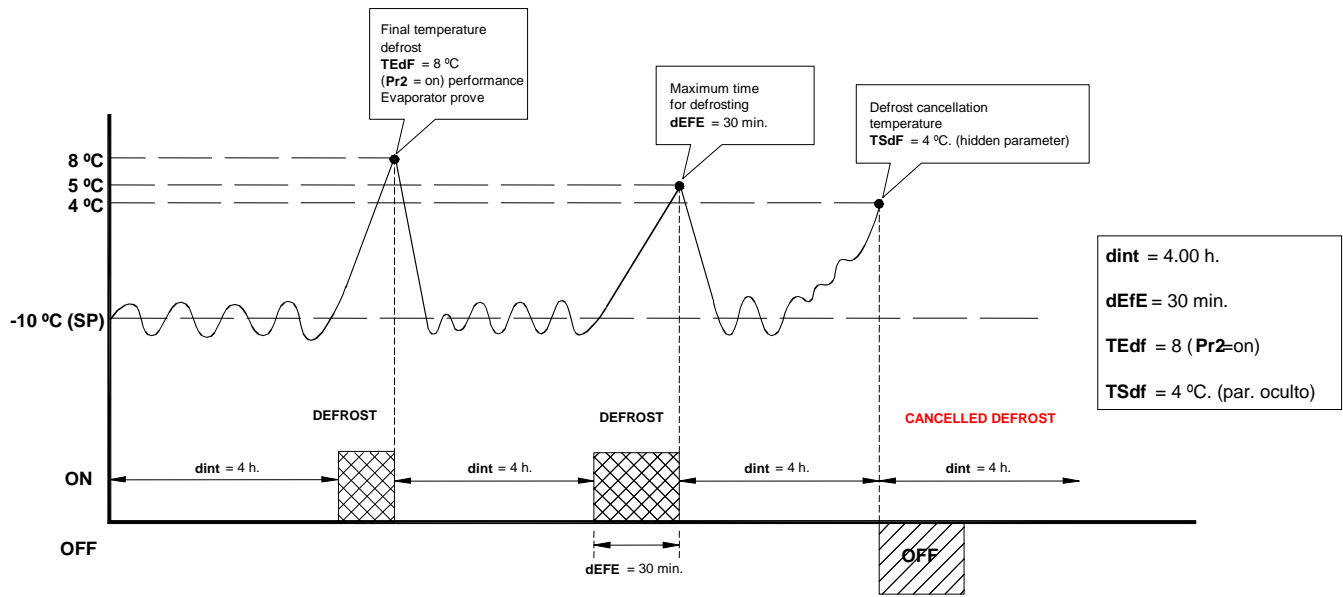

Example of real time defrosts

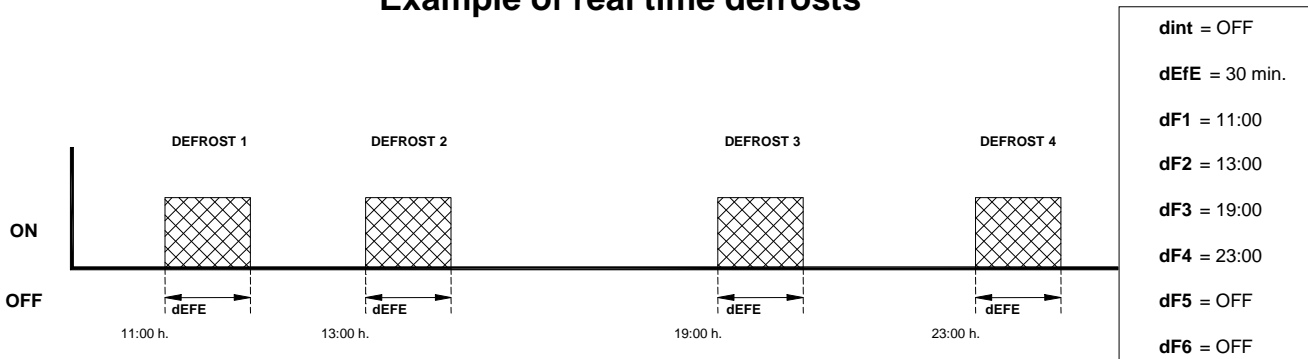

Compressor and fan operation

